

# Problem U

## Barrel Vaulted Structure

### Concrete

$E = 3600 \text{ ksi}$

Poissons Ratio = 0.2

12" thick concrete walls and slabs



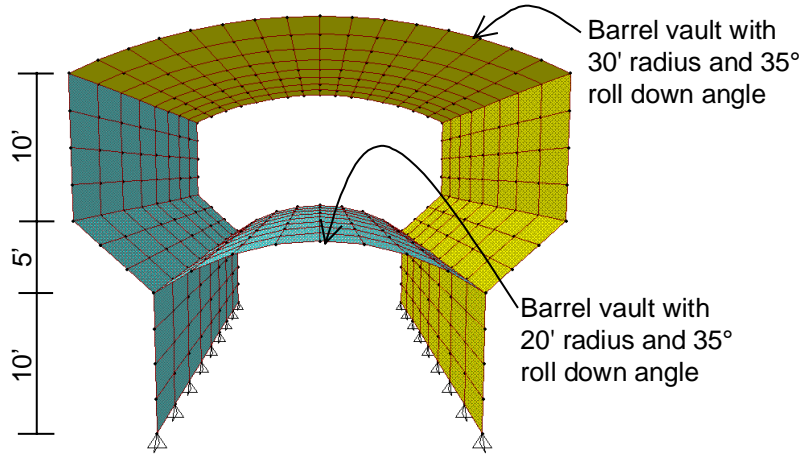
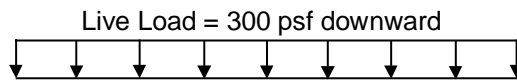
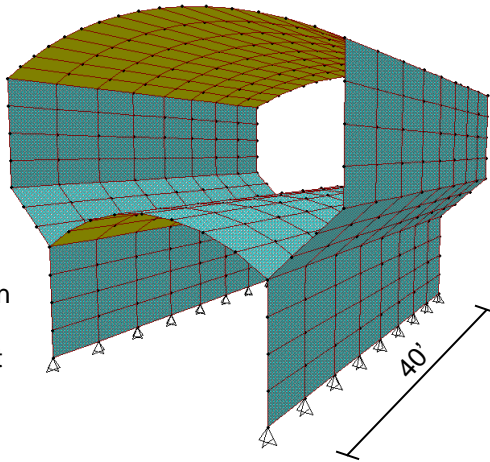

### To Do

Determine the maximum deflection at the center of upper and lower barrel vaults due to the self weight of the structure. Also determine the maximum deflection at center of upper and lower barrel vaults due to the self weight plus the prescribed live load applied to the top barrel vault.





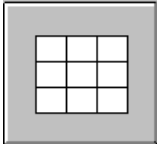

Note: Our intent is that you try this problem on your own first. After you have solved it on your own, you can step through our solution if desired. If you have problems trying to create the model, then follow the steps in our solution.

## **Problem U Solution**

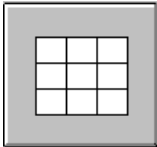
1. Click the drop down box in the status bar to change the units to kip-ft. 
2. From the **File** menu select **New Model From Template...** This displays the Model Templates dialog box.
3. In this dialog box click on the **Barrel** template  button to display the Barrel dialog box.
4. In this dialog box:
  - Accept the default Number of Circumferential Spaces, 8.
  - Accept the default Number of Span Spaces, 8.
  - Type **40** in the Span edit box.
  - Type **20** in the Radius edit box.
  - Type **35** in the Roll Down Angle edit box.
  - Uncheck the Restraints check box.
  - Click the **OK** button.
5. Click in the 3-D View window to make sure it is active. The window is highlighted when it is active.
6. Click the **Select All** button  located on the side toolbar to select the entire structure.
7. From the **Edit** menu select **Move...** to display the Move Selected Points dialog box.
8. In this dialog box:
  - Type **10** in the Delta Z edit box.
  - Click the **OK** button.
9. From the **Edit** menu select **Add To Model From Template...** to display the Model Templates dialog box.
10. In this dialog box click on the **Barrel** template  button to display the Barrel dialog box.
11. In this dialog box:

- Accept the default Number of Circumferential Spaces, 8.
  - Accept the default Number of Span Spaces, 8.
  - Type **40** in the Span edit box.
  - Type **30** in the Radius edit box.
  - Type **35** in the Roll Down Angle edit box.
  - Uncheck the Restraints check box if it is not already unchecked.
  - Click the **Advanced** button.
    - Type **25** in the Z edit box in the Translations area.
    - Click the **OK** button twice to exit all dialog boxes.
12. Click in the Y-Z Plane @ X=20 window to make sure it is active.
  13. Click the **Set Elements** button  on the main toolbar (or select **Set Elements...** from the **View** menu) to display the Set Elements Dialog box.
  14. In this dialog box:
    - Check the Labels box in the Joints area.
    - Click the **OK** button.
  15. Right click on joint 154 in window with the Y-Z Plane @ X=20. The Joint Information dialog box is displayed.
  16. Highlight the Y-coordinate (-17.2073) and press the Ctrl and the C keys on the keyboard at the same time to copy the value to the clipboard.
  17. Click the **Cancel** button to close the Joint Information dialog box.
  18. From the **Edit** menu select **Add To Model From Template...** to display the Model Templates dialog box.
  19. In this dialog box click on the **Shear Wall** template  button to display the Shear Wall dialog box.
  20. In this dialog box
    - Type **8** in the Number of Spaces Along X edit box.
    - Type **4** in the Number of Spaces Along Z edit box.

- Type **5** Space Width Along X edit box.
  - Type **2.5** Space Width Along Z edit box.
  - Uncheck the Restraints check box if it is not already unchecked.
  - Click the **Advanced** button.
    - Highlight the Y edit box and press the Ctrl and the V keys on the keyboard at the same time to paste the -17.2073 value from the clipboard.
    - Type **15** in the Z edit box in the Translations area.
    - Click the **OK** button twice to exit all dialog boxes.
21. Right click on joint 73 in window with the Y-Z Plane @ X=20. The Joint Information dialog box is displayed.
22. Highlight the Y-coordinate (-11.4715) and press the Ctrl and the C keys on the keyboard at the same time to copy the value to the clipboard.
23. Click the **Cancel** button to close the Joint Information dialog box.
24. From the **Edit** menu select **Add To Model From Template...** to display the Model Templates dialog box.
25. In this dialog box click on the **Shear Wall** template  button to display the Shear Wall dialog box.
26. In this dialog box
- Type **8** in the Number of Spaces Along X edit box.
  - Type **4** in the Number of Spaces Along Z edit box.
  - Type **5** Space Width Along X edit box.
  - Type **2.5** Space Width Along Z edit box.
  - Uncheck the Restraints check box if it is not already unchecked.
  - Click the **Advanced** button.
    - Highlight the Y edit box and press the Ctrl and the V keys on the keyboard at the same time to paste the -11.4715 value from the clipboard.
    - Click the OK button twice to exit all dialog boxes.
27. Click the **Pointer** button  on the side tool bar to enter select mode.

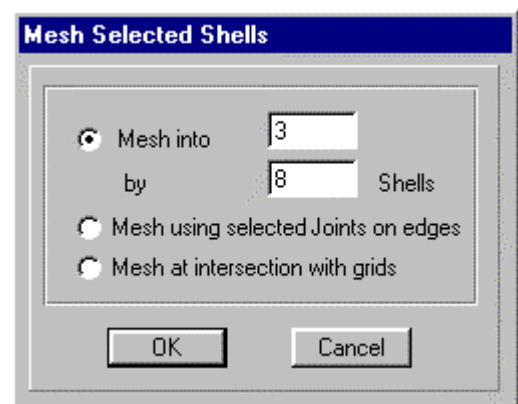

28. Click in the Y-Z Plane @ X=20 window to make sure it is active.
29. From the **View** menu select **Set 2D View...** to display the Set 2D View dialog box.
30. In this dialog box:
  - Select the X-Z Plane option.
  - Type **-11.4715** in the Y= edit box.
  - Click the **OK** button.
31. Select all of the elements in this view by “windowing”
32. From the **View** menu select **Set 2D View...** to display the Set 2D View dialog box.
33. In this dialog box:
  - Select the X-Z Plane option.
  - Type **-17.2073** in the Y= edit box.
  - Click the **OK** button.
34. Select all of the elements in this view by “windowing”
35. From the **View** menu select **Show Selection Only**.
36. Click the **Perspective Toggle** button  on the main toolbar.
37. From the **View** menu select **Show Grid** to toggle the grids off.
38. From the **View** menu select **Show Axes** to toggle the axes off.
39. From the **Draw** menu select **Draw Quad Shell Element**.
40. In the X-Z perspective view click on joints 163, 195, 73 and 1, in that order, to draw a shell element.
41. Click the **Pointer** button  on the side tool bar to exit draw mode and enter select mode.
42. Click on the just drawn shell element to select it.
43. From the **Edit** menu select **Mesh Shells...** to display the Mesh Selected Shells dialog box.
44. Fill in this dialog box as shown in the figure and







click the **OK** button.

*Note: It is difficult to figure out whether to mesh shells 3 by 8 or 8 by 3. It is often easiest to just go ahead and try one way, and if it isn't right, simply click the Undo button on the main toolbar and mesh the shells  other way.*

45. Select all of the elements in the X-Z perspective view by “windowing”.
46. From the **Edit** menu select **Replicate...** to display the Replicate dialog box.
47. In this dialog box:
  - Select the Mirror Tab.
  - In the Mirror About area select the XZ Plane option.
  - In the Ordinate area type **0** in the Y edit box if it is not already there.
  - Click the **OK** button.
48. From the **View** menu select **Set 2D View...** to display the Set 2D View dialog box.
49. In this dialog box:
  - Select the X-Y Plane option.
  - Type **0** in the Z= edit box.
  - Click the **OK** button.
50. Select all of the joints at this level by “windowing”.
51. From the Assign menu select Joint and then Restraints... from the submenu to display the Joint Restraints dialog box.
52. In this dialog box:
  - Verify that the Translation 1, 2 and 3 boxes are all checked.
  - Click the **OK** button.
53. From the **View** menu select **Set 2D View...** to display the Set 2D View dialog box.
54. In this dialog box:
  - Select the Y-Z Plane option.
  - Type **20** in the X= edit box.

- Click the **OK** button.
55. Click the **Show Undeformed Shape** button  to reset the window title.
  56. From the **View** menu select **Show All**.
  57. Click the drop down box in the status bar to change the units to kip-in. 
  58. From the **Define** menu select **Materials...** to display the Define Materials dialog box.
  59. Click on CONC in the Materials area to highlight (select) it, and then click the **Modify/Show Material** button. The Material Property Data dialog box is displayed.
  60. In this dialog box:
    - Type **3600** in the Modulus of Elasticity edit box.
    - Verify **.2** is entered in the Poisson's Ratio edit box.
    - Click the **OK** button twice to exit all dialog boxes.
  61. Click the drop down box in the status bar to change the units to kip-ft. 
  62. From the **Define** menu select **Materials...** to display the Define Materials dialog box.
  63. Click on CONC in the Materials area to highlight (select) it, and then click the **Modify/Show Material** button. The Material Property Data dialog box is displayed.
  64. In this dialog box:
    - Verify that **4.657E-03** is entered in the Mass Per Unit Volume edit box.
    - Verify that **.15** is entered in the Weight Per Unit Volume edit box.
    - Click the **OK** button twice to exit all dialog boxes.
  65. From the **Define** menu select **Shell Sections...** to display the Define Shell Sections dialog box.
  66. In this dialog box:
    - Click the **Modify/Show Section** button to display the Shell Sections dialog box.
    - In this dialog box:
      - Verify that the Material is CONC.
      - Verify that both the Membrane and Bending thicknesses are 1.



- Verify that the Shell option is chosen in the Type area.
  - Click the **OK** button twice to exit all dialog boxes.
67. From the **Define** menu select **Static Load Cases...** to display the Define Static Load Case Names dialog box.
68. In this dialog box:
- Type **DL** in the Load edit box.
  - Click the **Change Load** button.
  - Type **LL** in the Load edit box.
  - Select Live from the Type drop-down box.
  - Type **0** in the Self Weight Multiplier edit box.
  - Click the **Add New Load** button.
  - Click the **OK** button.
69. From the **Define** menu select **Load Combinations...** to display the Define Load Case Combinations dialog box.
70. In this dialog box:
- Click the **Add New Combo** button to display the Load Combination Data dialog box..
  - In this dialog box:
    - Accept the default Load Combination Name COMB1.
    - Accept the default Load Combination Type, Add.
    - Type **COMB1: DL + LL** in the Title edit box.
    - Verify that DL Load Case appears in the Case Name drop-down box, and that the Scale Factor is 1.
    - Click the **Add** button.
    - Select LL Load Case from the Case Name drop-down box
    - Click the **Add** button.
    - Click **OK** twice to exit all dialog boxes.



71. Click in the 3-D View window to activate it. Be careful not to accidentally select any members when you do this.
72. From the View menu select Set Limits... to display the Set Limits dialog box.
73. In this dialog box:
  - Type **25** in the Min edit box in the Set Z Axis limits area.
  - Click the **OK** button.
74. Select all of the displayed elements in the 3D View window (i.e., all elements in the roof barrel) by “windowing”.
75. From the **Assign** menu choose **Shell Static Loads...** and then choose **Uniform...** from the submenu to display the Shell Uniform Loads dialog box.
76. In this dialog box:
  - Select LL from the Load Case Name drop-down box.
  - Type **-.3** in the Load edit box.
  - Verify that Global Z is selected in the Dir drop-down box.
  - Click the **OK** button.
77. Click the **Show Undeformed Shape** button  to remove the display of shell uniform loads and to remove the limits that were set.
78. Click the **Run Analysis** button  to run the analysis.
79. When the analysis is complete check the messages in the Analysis window (there should be no warnings or errors) and then click the **OK** button to close the Analysis window.
80. Click in the window titled Y-Z Plane @ X=20 to activate it.
81. Click the **Display Static Deformed Shape** button  on the main toolbar to display the Deformed Shape dialog box.
82. In this dialog box:
  - Select the DL Load Case from the Load drop-down box.
  - Select the Auto Scaling option.
  - Click the **OK** button.
83. Click the drop down box in the status bar to change the units to kip-in. 

84. Right click on the center joint of the upper barrel vault to see its self weight displacement in inches.
85. Right click on the center joint of the lower barrel vault to see its self weight displacement in inches.
86. Click the **Display Static Deformed Shape** button  on the main toolbar to display the Deformed Shape dialog box.
87. In this dialog box:
  - Select the COMB1 Combo from the Load drop-down box.
  - Click the **OK** button.
88. Right click on the center joint of the upper barrel vault to see its self weight plus live load displacement in inches.
89. Right click on the center joint of the lower barrel vault to see its self weight plus live load displacement in inches.

## Alternative Problem U Solution

Now an alternative method of creating the model is shown. This alternative method does not use the Advanced button feature of the **Add To Model From Template** feature. Instead it makes use of groups and the move command to accomplish essentially the same thing. It is a good example of one of the uses of groups. This alternative method takes more steps than the initial method shown. The initial method is recommended; this method is just shown for example purposes.

- A1. Click the drop down box in the status bar to change the units to kip-ft. 
- A2. From the **File** menu select **New Model From Template...** This displays the Model Templates dialog box.
- A3. In this dialog box click on the **Barrel Template**  button to display the Barrel dialog box.
- A4. In this dialog box
  - Accept the default Number of Circumferential Spaces, 8.
  - Accept the default Number of Span Spaces, 8.

- Type **40** in the Span edit box.
  - Type **20** in the Radius edit box.
  - Type **35** in the Roll Down Angle edit box.
  - Uncheck the Restraints check box.
  - Click the **OK** button.
- A5. Click in the 3-D View window to make sure it is active. The window is highlighted when it is active.
- A6. Click the **Select All** button  located on the side toolbar to select the entire structure.
- A7. From the **Assign** menu select **Group Name...** to display the Assign Group dialog box.
- A8. In this dialog box:
- Type **LOBARREL** in the Groups edit box.
  - Click the **Add New Group Name** button.
  - Click the **OK** button.
- A9. Click the **Restore Previous Selection** button  on the side toolbar (or select **Get Previous Selection** from the **Select** menu).
- A10. From the **Edit** menu select **Move...** to display the Move Selected Points dialog box.
- A11. In this dialog box:
- Type **10** in the Delta Z edit box.
  - Click the **OK** button.
- A12. From the **Edit** menu select **Add To Model From Template...** to display the Model Templates dialog box.
- A13. In this dialog box click on the **Barrel** template  button to display the Barrel dialog box.
- A14. In this dialog box
- Accept the default Number of Circumferential Spaces, 8.
  - Accept the default Number of Span Spaces, 8.
  - Type **40** in the Span edit box.

- Type **30** in the Radius edit box.
- Type **35** in the Roll Down Angle edit box.
- Uncheck the Restraints check box if it is not already unchecked.
- Click the **OK** button.

A15. Click the **Pointer** button  on the side tool bar to enter select mode.

A16. Click the **Select All** button  located on the side toolbar to select the entire structure.

A17. From the **Select** menu choose **Deselect** and then choose **Groups...** from the submenu to display the Select Groups dialog box.

A18. In this dialog box:

- Click on the LOBARREL group to highlight it.
- Click the **OK** button.

A19. From the **Assign** menu select **Group Name...** to display the Assign Group dialog box.

A20. In this dialog box:

- Type **HIBARREL** in the Groups edit box.
- Click the **Add New Group Name** button.
- Click the **OK** button.

A21. Click the **Restore Previous Selection** button  on the side toolbar (or select **Get Previous Selection** from the **Select** menu).

A22. From the **Edit** menu select **Move...** to display the Move Selected Points dialog box.

A23. In this dialog box:

- Type **25** in the Delta Z edit box.
- Click the **OK** button.

A24. From the **Edit** menu select **Add To Model From Template...** to display the Model Templates dialog box.

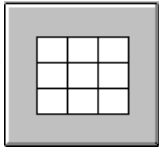
A25. In this dialog box click on the **Shear Wall** template  button to display the Shear Wall dialog box.

A26. In this dialog box

- Type **8** in the Number of Spaces Along X edit box.
- Type **4** in the Number of Spaces Along Z edit box.
- Type **5** Space Width Along X edit box.
- Type **2.5** Space Width Along Z edit box.
- Uncheck the Restraints check box if it is not already unchecked.
- Click the **OK** button.

A27. Click the **Pointer** button  on the side tool bar to enter select mode.

A28. Click the **Select All** button  located on the side toolbar to select the entire structure.

A29. From the **Select** menu choose **Deselect** and then choose **Groups...** from the submenu to display the Select Groups dialog box.

A30. In this dialog box:

- Click on the HIBARREL group to highlight it.
- Hold down on the Ctrl key on the keyboard and click on the LOBARREL group to add it to the selection
- Click the **OK** button.

A31. From the **Assign** menu select **Group Name...** to display the Assign Group dialog box.

A32. In this dialog box:

- Type **WALL1** in the Groups edit box.
- Click the **Add New Group Name** button.
- Click the **OK** button.

A33. Click in the Window titled Y-Z Plane @ X=20 to activate it.

A34. Click the **Set Elements** button  on the main toolbar (or select **Set Elements...** from the **View** menu) to display the Set Elements Dialog box.

A35. In this dialog box:

- Check the Labels box in the Joints area.
- Click the **OK** button.

A36. Right click on joint 154. The Joint Information dialog box is displayed.

A37. In this dialog box:

- Note that the Y-coordinate of this joint is -17.2073.
- Click the **OK** button to close the dialog box.

A38. From the **Select** menu choose **Select** and then choose **Groups...** from the submenu to display the Select Groups dialog box.

A39. In this dialog box:

- Click on the WALL1 group to highlight it.
- Click the **OK** button.

A40. From the **Edit** menu select **Move...** to display the Move Selected Points dialog box.

A41. In this dialog box:

- Type **-17.2073** in the Delta Y edit box.
- Type **15** in the Delta Z edit box.
- Click the **OK** button.

A42. Right click on joint 73. The Joint Information dialog box is displayed.

A43. In this dialog box:

- Note that the Y-coordinate of this joint is -11.4715.
- Note that the Y-direction distance between joints 154 and 73 can be calculated as  $17.2073 - 11.4715 = 5.7358$ .
- Click the **OK** button to close the dialog box.

A44. From the **Select** menu choose **Select** and then choose **Groups...** from the submenu to display the Select Groups dialog box.

A45. In this dialog box:

- Click on the WALL1 group to highlight it.
- Click the **OK** button.

A46. From the **Edit** menu select **Replicate...** to display the Replicate dialog box.

A47. In this dialog box:

- Select the Linear Tab.
- Type **5.7358** in the Y Distance edit box.
- Type **-15** in the Z Distance edit box.
- Type **1** in the Number edit box.
- Click the **OK** button.

A48. Click the **Select All** button  located on the side toolbar to select the entire structure.

A49. From the **Select** menu choose **Deselect** and then choose **Groups...** from the submenu to display the Select Groups dialog box.

A50. In this dialog box:

- Click on the HIBARREL group to highlight it.
- Hold down on the Ctrl key on the keyboard and click on the LOBARREL group to add it to the selection
- Click the **OK** button.

A51. From the **View** menu select **Show Selection Only**.

A52. From the **View** menu select **Set 2D View...** to display the Set 2D View dialog box.

A53. In this dialog box:

- Select the X-Z Plane option.
- Type **-17.2073** in the Y= edit box.
- Click the **OK** button.

A54. Click the **Perspective Toggle** button  on the main toolbar.

A55. From the **View** menu select Show Grid to toggle the grids off.

A56. From the **Draw** menu select **Draw Quad Shell Element**.

A57. In the X-Z perspective view click on joints 163, 203, 73 and 1, in that order, to draw a shell element.

A58. Click the **Pointer** button  on the side tool bar to exit draw mode and enter select mode.

A59. Click on the just drawn shell element to select it.

A60. From the **Edit** menu select **Mesh Shells...** to display the Mesh Selected Shells dialog box.

A61. Fill in this dialog box as shown in the figure and click the **OK** button.

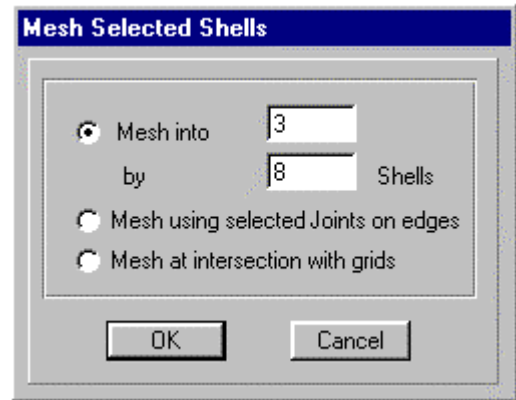

*Note: It is difficult to figure out whether to mesh shells 3 by 8 or 8 by 3. It is often easiest to just go ahead and try one way, and if it isn't right, simply click the Undo button  on the main toolbar and mesh the shells the other way.*

A62. Select all of the elements in the X-Z perspective view by “windowing”.

A63. From the **Edit** menu select **Replicate...** to display the Replicate dialog box.

A64. In this dialog box:

- Select the Mirror Tab.
- In the Mirror About area select the XZ Plane option.
- In the Ordinate area type **0** in the Y edit box if it is not already there.
- Click the **OK** button.

A65. From the **View** menu select **Set 2D View...** to display the Set 2D View dialog box.

A66. In this dialog box:

- Select the X-Y Plane option.
- Type **0** in the Z= edit box.
- Click the **OK** button.

A67. Select all of the joints at this level by “windowing”.

A68. From the **Assign** menu select **Joint** and then **Restraints...** from the submenu to display the Joint Restraints dialog box.

A69. In this dialog box:

- Verify that the Translation 1, 2 and 3 boxes are all checked.

- Click the OK button.

A70. From the **View** menu select **Set 2D View...** to display the Set 2D View dialog box.

A71. In this dialog box:

- Select the Y-Z Plane option.
- Type **20** in the X= edit box.
- Click the **OK** button.

A72. Click the **Show Undeformed Shape** button  to reset the window title.

A73. From the **View** menu select **Show All**.

A74. Click the drop down box in the status bar to change the units to kip-in. 

A75. From the **Define** menu select **Materials...** to display the Define Materials dialog box.

A76. Click on CONC in the Materials area to highlight (select) it, and then click the **Modify/Show Material** button. The Material Property Data dialog box is displayed.

A77. In this dialog box:

- Type **3600** in the Modulus of Elasticity edit box.
- Verify **.2** is entered in the Poisson's Ratio edit box.
- Click the **OK** button twice to exit all dialog boxes.

A78. Click the drop down box in the status bar to change the units to kip-ft. 

A79. From the **Define** menu select **Materials...** to display the Define Materials dialog box.

A80. Click on CONC in the Materials area to highlight (select) it, and then click the **Modify/Show Material** button. The Material Property Data dialog box is displayed.

A81. In this dialog box:

- Verify that **4.657E-03** is entered in the Mass Per Unit Volume edit box.
- Verify that **.15** is entered in the Weight Per Unit Volume edit box.
- Click the **OK** button twice to exit all dialog boxes.

A82. From the **Define** menu select **Shell Sections...** to display the Define Shell Sections dialog box.

A83. In this dialog box:

- Click the **Modify/Show Section** button to display the Shell Sections dialog box.
- In this dialog box:
  - Verify that the Material is CONC.
  - Verify that both the Membrane and Bending thicknesses are 1.
  - Verify that the Shell option is chosen in the Type area.
  - Click the **OK** button twice to exit all dialog boxes.

A84. From the **Define** menu select **Static Load Cases...** to display the Define Static Load Case Names dialog box.

A85. In this dialog box:

- Type **DL** in the Load edit box.
- Click the **Change Load** button.
- Type **LL** in the Load edit box.
- Select Live from the Type drop-down box.
- Type **0** in the Self Weight Multiplier edit box.
- Click the **Add New Load** button.
- Click the **OK** button.

A86. From the **Define** menu select **Load Combinations...** to display the Define Load Case Combinations dialog box.

A87. In this dialog box:

- Click the Add New Combo button to display the Load Combination Data dialog box..
- In this dialog box:
  - Accept the default Load Combination Name COMB1.
  - Accept the default Load Combination Type, Add.
  - Type **COMB1: DL + LL** in the Title edit box.

- Verify that DL Load Case appears in the Case Name drop-down box, and that the Scale Factor is 1.
- Click the **Add** button.
- Select LL Load Case from the Case Name drop-down box
- Click the **Add** button.
- Click **OK** twice to exit all dialog boxes.

A88. Click in the 3-D View window to activate it. Be careful not to accidentally select any members when you do this.

A89. From the **Select** menu choose **Select** and then choose **Groups...** from the submenu to display the Select Groups dialog box.

A90. In this dialog box:

- Click on the HIBARREL group to highlight it.
- Click the **OK** button.

A91. From the **Assign** menu choose **Shell Static Loads...** and then choose **Uniform...** from the submenu to display the Shell Uniform Loads dialog box.

A92. In this dialog box:

- Select LL from the Load Case Name drop-down box.
- Type **-.3** in the Load edit box.
- Verify that Global Z is selected in the Dir drop-down box.
- Click the **OK** button.

A93. Click the **Show Undeformed Shape** button  to remove the display of shell uniform loads.

A94. Click the **Run Analysis** button  to run the analysis.

A95. When the analysis is complete check the messages in the Analysis window (there should be no warnings or errors) and then click the **OK** button to close the Analysis window.

A96. Click in the window titled Y-Z Plane @ X=20 to activate it.

A97. Click the **Display Static Deformed Shape** button  on the main toolbar to display the Deformed Shape dialog box.

A98. In this dialog box:

- Select the DL Load Case from the Load drop-down box.
- Select the Auto Scaling option.
- Click the **OK** button.

A99. Click the drop down box in the status bar to change the units to kip-in. 

A100. Right click on the center joint of the upper barrel vault to see its self weight displacement in inches.

A101. Right click on the center joint of the lower barrel vault to see its self weight displacement in inches.

A102. Click the **Display Static Deformed Shape** button  on the main toolbar to display the Deformed Shape dialog box.

A103. In this dialog box:

- Select the COMB1 Combo from the Load drop-down box.
- Click the **OK** button.

A104. Right click on the center joint of the upper barrel vault to see its self weight plus live load displacement in inches.

A105. Right click on the center joint of the lower barrel vault to see its self weight plus live load displacement in inches.